

# Axial Piston Fixed Pump A2FO

**RE 91401/03.08** 1/24  
Replaces: 09.07

## Technical data sheet

Series 6	
Sizes	Nominal pressure/Peak pressure
5	315/350 bar
10 to 200	400/450 bar
250 to 1000	350/400 bar
Open circuits	



## Contents

Ordering Code / Standard Program	2
Technical Data	3..7
Ordering Code / Unit Dimensions, Size 5	8
Unit Dimensions, Sizes 10, 12, 16	9
Unit Dimensions, Sizes 23, 28, 32	10
Unit Dimensions, Size 45	11
Unit Dimensions, Sizes 56, 63	12
Unit Dimensions, Sizes 80, 90	13
Unit Dimensions, Sizes 107, 125	14
Unit Dimensions, Sizes 160, 180	15
Unit Dimensions, Size 200	16
Unit Dimensions, Size 250	17
Unit Dimensions, Size 355	18
Unit Dimensions, Size 500	19
Unit Dimensions, Size 710	20
Unit Dimensions, Size 1000	21
Installation Notes	22
General Notes	24

## Features

- Fixed pump with axial tapered piston rotary group of bent axis design, for hydrostatic drives in open circuits
- For use in mobile and stationary application areas
- Output flow is proportional to drive speed and displacement
- The drive shaft bearings are designed to give the service life expected in these areas of operation
- High power density
- Compact design
- High overall efficiency
- Economical conception
- One piece pistons with piston rings



# Technical Data

## Hydraulic fluid

Before starting project planning, please refer to our data sheets RE 90220 (mineral oil), RE 90221 (environmentally acceptable hydraulic fluids) and RE 90223 (HF hydraulic fluids) for detailed information regarding the choice of hydraulic fluid and application conditions.

The fixed pump A2FO is unsuitable for operation with HFA. If HFB, HFC and HFD or environmentally acceptable hydraulic fluids are being used, the limitations regarding technical data and seals mentioned in RE 90221 and RE 90223 must be observed.

When ordering, please indicate the used hydraulic fluid.

## Operating viscosity range

For optimum efficiency and service life, select an operating viscosity (at operating temperature) within the optimum range of

$$v_{\text{opt}} = \text{optimum operating viscosity } 16 \text{ to } 36 \text{ mm}^2/\text{s}$$

depending on the tank temperature (closed circuit) and tank temperature (open circuit).

## Limits of viscosity range

The limiting values for viscosity are as follows:

Sizes 5 to 200:

$v_{\text{min}} = 5 \text{ mm}^2/\text{s}$ ,  
short-term ( $t < 3 \text{ min}$ )  
at max. perm. temperature of  $t_{\text{max}} = +115^\circ\text{C}$ .

$v_{\text{max}} = 1600 \text{ mm}^2/\text{s}$ ,  
short-term ( $t < 3 \text{ min}$ )  
at cold start ( $p \leq 30 \text{ bar}$ ,  $n \leq 1000 \text{ rpm}$ ,  $t_{\text{min}} = -40^\circ\text{C}$ )  
Only for starting up without load. Optimum operating viscosity must be reached within approx. 15 minutes.

Sizes 250 to 1000:

$v_{\text{min}} = 10 \text{ mm}^2/\text{s}$ ,  
short-term ( $t < 3 \text{ min}$ )  
at max. perm. temperature of  $t_{\text{max}} = +90^\circ\text{C}$ .

$v_{\text{max}} = 1000 \text{ mm}^2/\text{s}$ ,  
short-term ( $t < 3 \text{ min}$ )  
at cold start ( $p \leq 30 \text{ bar}$ ,  $n \leq 1000 \text{ rpm}$ ,  $t_{\text{min}} = -25^\circ\text{C}$ ).  
Only for starting up without load. Optimum operating viscosity must be reached within approx. 15 minutes.

Note that the maximum hydraulic fluid temperature of  $115^\circ\text{C}$  ( $90^\circ\text{C}$  at size 250 to 1000) must not be exceeded locally either (e.g. in the bearing area). The temperature in the bearing area is - depending on pressure and speed - up to 12 K higher than the average case drain temperature.

Special measures are necessary in the temperature range from  $-40^\circ\text{C}$  and  $-25^\circ\text{C}$  (cold start phase), please contact us.

For detailed information about use at low temperatures, see RE 90300-03-B.

## Selection diagram

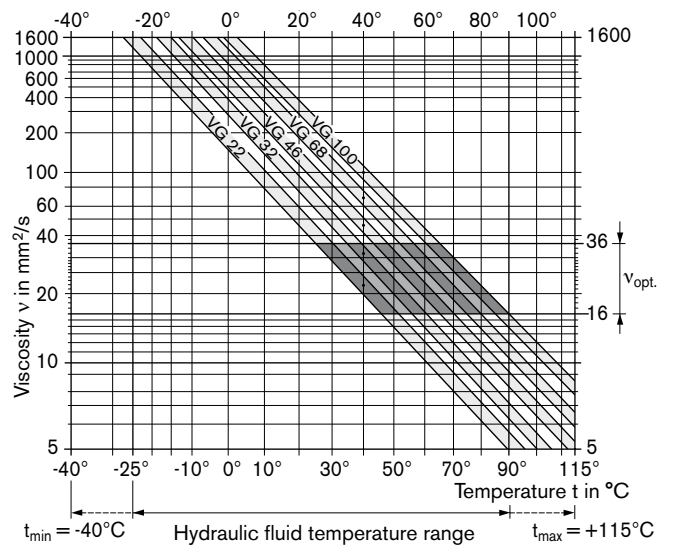

## Details regarding the choice of hydraulic fluid

The correct choice of hydraulic fluid requires knowledge of the operating temperature in relation to the ambient temperature: in an open circuit the tank temperature.

The hydraulic fluid should be chosen so that the operating viscosity in the operating temperature range is within the optimum range ( $v_{\text{opt}}$ ) - the shaded area of the selection diagram. We recommended that the higher viscosity class be selected in each case.

Example: At an ambient temperature of  $X^\circ\text{C}$  an operating temperature of  $60^\circ\text{C}$  is set. In the optimum operating viscosity range ( $v_{\text{opt}}$ ; shaded area) this corresponds to the viscosity classes VG 46 or VG 68; to be selected: VG 68.

## Please note:

The case drain temperature, which is affected by pressure and speed, is always higher than the tank temperature. At no point in the system may the temperature be higher than  $115^\circ\text{C}$  for sizes 5 to 200 or  $90^\circ\text{C}$  for sizes 250 to 1000.

If the above conditions cannot be maintained due to extreme operating parameters, we recommend flushing the case at port U (size 250 to 1000).

## Filtration

The finer the filtration, the higher the cleanliness level of the hydraulic fluid and the longer the service life of the axial piston unit.

To ensure functional reliability of the axial piston unit, the hydraulic fluid must have a cleanliness level of at least

20/18/15 according to ISO 4406.

At very high hydraulic fluid temperatures ( $90^\circ\text{C}$  to max.  $115^\circ\text{C}$ , not permitted for sizes 250 to 1000) at least cleanliness level

19/17/14 according to ISO 4406 is required.

If the above classes cannot be observed, please contact us.

# Technical Data

## Operational pressure range

### Inlet

Pressure at port S

The minimum inlet pressure depends on speed. The following limits must not be exceeded.

$p_{abs \min}$  \_\_\_\_\_ 0,8 bar

$p_{abs \max}$  \_\_\_\_\_ 30 bar

### Minimum inlet pressure at suction port S with increased speed

In order to avoid damage of the pump a minimum inlet pressure at the suction port must be assured. The minimum inlet pressure is related to the rotational speed of the fixed pump.

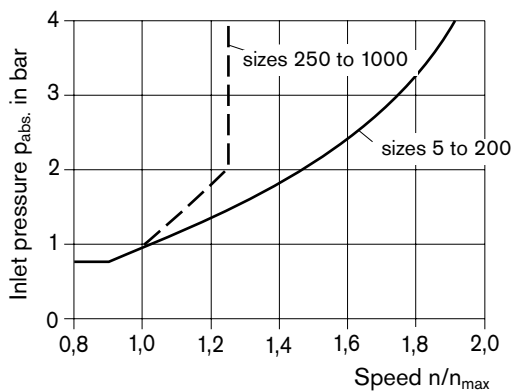

### Note:

- max. permissible speed  $n_{\max \text{ perm.}}$  (speed limit)
- min. permissible inlet pressure at port S
- admissible values for the drive shaft seal

### Outlet

Maximum pressure on port A or B  
(pressure data according to DIN 24312)

Size 5	Shaft end B	Shaft end C
Nominal pressure $p_N$	210 bar	315 bar
Peak pressure $p_{\max}$	250 bar	350 bar

Sizes 10 to 200	Shaft end A, Z <sup>1)</sup>	Shaft end B, P
Nominal pressure $p_N$	400 bar	350 bar
Peak pressure $p_{\max}$	450 bar	400 bar

### Sizes 250 to 1000

Nominal pressure $p_N$	350 bar
Peak pressure $p_{\max}$	400 bar

<sup>1)</sup> size 56 with shaft end Z:  $p_N = 350$  bar,  $p_{\max} = 400$  bar

### Please note:

Sizes 10 to 200: With shaft end Z and P, a nominal pressure of  $p_N = 315$  bar ( $p_{\max} = 350$  bar) is permissible for drives with radial loading of the drive shaft (pinions, V-belts)!

Sizes 250 to 1000: Please contact us.

In cases of pulsating loading above 315 bar, we recommend the version with splined shaft A (sizes 10 to 200) or with splined shaft Z (sizes 45, 250 to 1000).

### Direction of flow

Direction of rotation, viewed on shaft end	
clockwise	counter-clockwise
<b>S to B</b>	<b>S to A</b>

### Long-life bearing (sizes 250 to 1000)

For long service life and use with HF hydraulic fluids. Same external dimensions as pump with standard bearing. A long-life bearing can be specified. Flushing of bearing and case via port U recommended.

### Flushing volumes (recommended)

Size	250	355	500	710	1000
$q_{V \text{ flush}}$ (L/min)	10	16	16	16	16

### Symbol

#### Connections

A, B	Service line port
S	Suction port
T <sub>1</sub> , T <sub>2</sub>	Drain ports
R/U	Port for bearing flushing

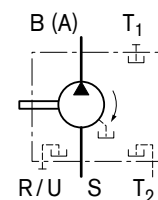

# Technical Data

## Shaft seal ring

### Permissible pressure loading for shaft seal ring FKM

The service life of the shaft seal ring is affected by the speed of the pump and the case drain pressure. It is recommended that the average, continuous case drain pressure at operating temperature 3 bar absolute not be exceeded (max. permissible case drain pressure 6 bar absolute at reduced speed, see diagram). Short term ( $t < 0.1$  s) pressure spikes of up to 10 bar absolute are permitted. The service life of the shaft seal ring decreases with an increase in the frequency of pressure spikes.

The case pressure must be equal to or greater than the external pressure on the shaft seal ring.

#### Sizes 10 to 200

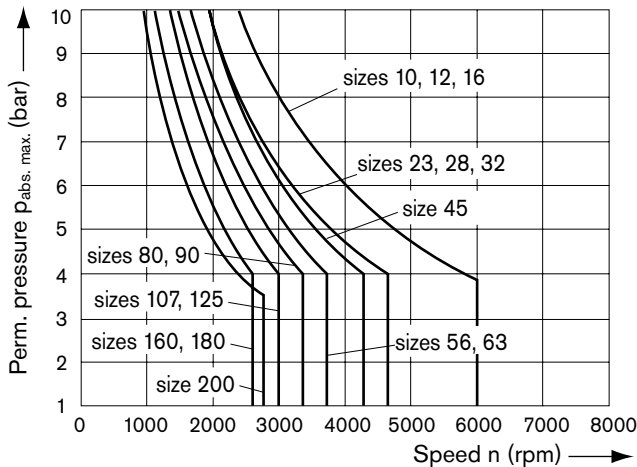

#### Sizes 250 to 1000

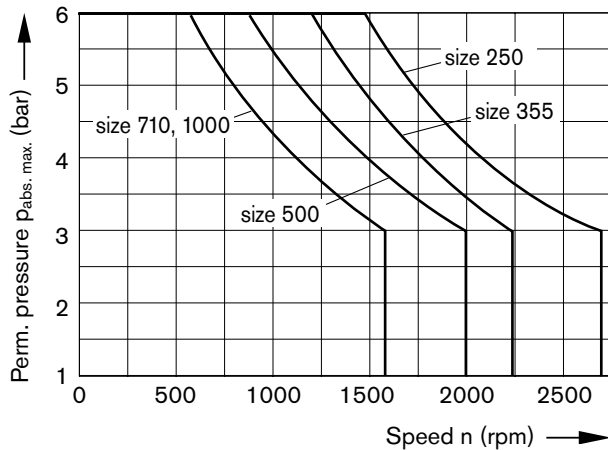

### Permissible pressure loading for shaft seal ring NBR

sizes 5...200

For shaft seal rings of NBR 33% reduced values for the max. permissible case pressure  $p_{abs. max.}$  are to be considered compared with seals of FKM.

### Temperature range

The FKM shaft seal ring is permissible for case temperatures of  $-25^{\circ}\text{C}$  to  $+115^{\circ}\text{C}$  at sizes 5 to 200 and  $-25^{\circ}\text{C}$  to  $+90^{\circ}\text{C}$  at sizes 250 to 1000

#### Note:

For application cases below  $-25^{\circ}\text{C}$ , an NBR shaft seal ring is necessary (permissible temperature range:  $-40^{\circ}\text{C}$  to  $+90^{\circ}\text{C}$ .) Please contact us.

# Technical Data

**Table of values** (theoretical values, without efficiency and tolerances; values rounded)

Size			5	10	12	16	23	28	32	45	56	63	80
Displacement	$V_g$	cm <sup>3</sup>	4,93	10,3	12	16	22,9	28,1	32	45,6	56,1	63	80,4
Max. speed	$n_{max}^1)$	rpm	5600	3150	3150	3150	2500	2500	2500	2240	2000	2000	1800
	$n_{max\ limit}^2)$	rpm	8000	6000	6000	6000	4750	4750	4750	4250	3750	3750	3350
Max. flow at $n_{max}$	$q_{V\ max}$	L/min	27,6	32,4	37,8	50	57	70	80	102	112	126	144
Power at	$\Delta p = 350\ bar$ $P_{max}$	kW	14,5 <sup>3)</sup>	18,9	22	29,2	33	41	47	59,5	65	73,5	84
	$\Delta p = 400\ bar$ $P_{max}$	kW	–	21,6	25	34	38	47	53	68	75	84	96
Torque at	$\Delta p = 350\ bar$ T	Nm	24,7 <sup>3)</sup>	57	67	88	126	156	178	254	312	350	445
	$\Delta p = 400\ bar$ T	Nm	–	65	76	101	145	178	203	290	356	400	511
Rotary stiffness	c	Nm/rad	625	922	1250	1590	2560	2930	3120	4180	5940	6250	8730
Moment of inertia - for rotary group	$J_{TW}$	kgm <sup>2</sup>	0,00006	0,0004	0,0004	0,0004	0,0012	0,0012	0,0012	0,0024	0,0042	0,0042	0,0072
Angular acceleration max.	$\alpha$	rad/s <sup>2</sup>	5000	5000	5000	5000	6500	6500	6500	14600	7500	7500	6000
Filling capacity	V	L		0,17	0,17	0,17	0,20	0,20	0,20	0,33	0,45	0,45	0,55
Mass (approx.)	m	kg	2,5	6	6	6	9,5	9,5	9,5	13,5	18	18	23

Size			90	107	125	160	180	200	250	355	500	710	1000
Displacement	$V_g$	cm <sup>3</sup>	90	106,7	125	160,4	180	200	250	355	500	710	1000
Max. speed	$n_{max}^1)$	rpm	1800	1600	1600	1450	1450	1550	1500	1320	1200	1200	950
	$n_{max\ limit}^2)$	rpm	3350	3000	3000	2650	2650	2750	1800	1600	1500	1500	1200
Max. flow at $n_{max}$	$q_{V\ max}$	L/min	162	170	200	232	261	310	375	469	600	826	950
Power at	$\Delta p = 350\ bar$ $P_{max}$	kW	95	100	117	135	152	181	219	273	350	497	554
	$\Delta p = 400\ bar$ $P_{max}$	kW	108	114	133	155	174	207	–	–	–	–	–
Torque at	$\Delta p = 350\ bar$ T	Nm	501	594	696	893	1003	1114	1393	1978	2785	3955	5570
	$\Delta p = 400\ bar$ T	Nm	572	678	795	1020	1145	1272	–	–	–	–	–
Rotary stiffness	c	Nm/rad	9140	11200	11900	17400	18200	57300	73100	96100	144000	270000	324000
Moment of inertia - for rotary group	$J_{TW}$	kgm <sup>2</sup>	0,0072	0,0116	0,0116	0,0220	0,0220	0,0353	0,061	0,102	0,178	0,55	0,55
Angular acceleration max.	$\alpha$	rad/s <sup>2</sup>	6000	4500	4500	3500	3500	11000	10000	8300	5500	4300	4000
Filling capacity	V	L	0,55	0,8	0,8	1,1	1,1	2,7	2,5	3,5	4,2	8	8
Mass (approx.)	m	kg	23	32	32	45	45	66	73	110	155	325	336

<sup>1)</sup> The values shown are valid for an absolute pressure ( $p_{abs}$ ) of 1 bar at the suction inlet S and when operated on mineral oil (with a specific mass of 0,88 kg/L).

<sup>2)</sup> By increase of the input pressure ( $p_{abs} > 1\ bar$ ) the rotational speeds can be increased to the max. admissible speeds  $n_{max\ limit}$  (speed limits) (see diagram page 4).

<sup>3)</sup> Torque at  $\Delta p = 315\ bar$

**Caution:** Exceeding the permissible limit values may result in a loss of function, a reduction in service life or in the destruction of the axial piston unit.

Other permissible limit values with respect to speed variation, reduced angular acceleration as a function of the frequency and the permissible startup angular acceleration (lower than the maximum angular acceleration) can be found in data sheet RE 90261.



## Determining the size



Flow	$q_v = \frac{V_g \cdot n \cdot \eta_v}{1000}$	L/min	$V_g =$ Displacement per revolution in cm <sup>3</sup>
			$\Delta p =$ Differential pressure in bar
			$n =$ Speed in rpm
Torque	$T = \frac{V_g \cdot \Delta p}{20 \cdot \pi \cdot \eta_{mh}}$	Nm	$\eta_v =$ Volumetric efficiency
			$\eta_{mh} =$ Mechanical-hydraulic efficiency
Power	$P = \frac{2 \pi \cdot T \cdot n}{60000} = \frac{q_v \cdot \Delta p}{600 \cdot \eta_t}$	kW	$\eta_t =$ Overall efficiency

# Technical Data

## Permissible radial and axial loading on the drive shaft

The specified values given are maximum values and do not apply to continuous operation.

Size				5	10	12	16	23	28	32	45	56	63	80
Radial force, max. <sup>1)</sup> at distance a (from shaft collar)		$F_{q \max}$	N	710	2350	2750	3700	4300	5400	6100	8150 <sup>2)</sup>	9200 <sup>2)</sup>	10300	11500 <sup>2)</sup>
		a	mm	12	16	16	16	16	16	16	18	18	18	20
Axial force, max. <sup>3)</sup>		$+F_{ax \max}$	N	180	320	320	320	500	500	500	630	800	800	1000
		$-F_{ax \max}$	N	180	320	320	320	500	500	500	630	800	800	1000
Permissible axial force/bar operating pressure		$\pm F_{ax \text{ per.}}/\text{bar}$	N/bar	1,5	3,0	3,0	3,0	5,2	5,2	5,2	7,0	8,7	8,7	10,6

Size				90	107	125	160	180	200	250	355	500	710	1000
Radial force, max. <sup>1)</sup> at distance a (from shaft collar)		$F_{q \max}$	N	12900	13600	15900	18400	20600	22900	1200 <sup>4)</sup>	1500 <sup>4)</sup>	1900 <sup>4)</sup>	3000 <sup>4)</sup>	2600 <sup>4)</sup>
		a	mm	20	20	20	25	25	25	41	52,5	52,5	67,5	67,5
Axial force, max. <sup>3)</sup>		$+F_{ax \max}$	N	1000	1250	1250	1600	1600	1600	2000	2500	3000	4400	4400
		$-F_{ax \max}$	N	1000	1250	1250	1600	1600	1600	2000	2500	3000	4400	4400
Permissible axial force/bar operating pressure		$\pm F_{ax \text{ per.}}/\text{bar}$	N/bar	10,6	12,9	12,9	16,7	16,7	16,7	<sup>5)</sup>	<sup>5)</sup>	<sup>5)</sup>	<sup>5)</sup>	<sup>5)</sup>

<sup>1)</sup> During intermittent operation (sizes 5 to 200)

<sup>2)</sup> Permissible max. radial force with shaft end Z:  $F_{q \max} = 6500$  N

<sup>3)</sup> Max. permissible axial force when at a standstill or when axial piston unit working in pressureless conditions

<sup>4)</sup> When at a standstill or when axial piston unit operating in depressurized condition. Higher forces are permissible when under pressure. Please contact us.

<sup>5)</sup> Please contact us

When considering the permissible axial force, the force-transfer direction must be taken into account:

$-F_{ax \max}$  = increase in service life of bearings

$+F_{ax \max}$  = reduction in service life of bearings (avoid)

### Effect of radial force $F_q$ on the service life of the bearings

By selecting a suitable force-transfer direction of  $F_q$ , the stress on the bearing caused by the internal transmission forces can be reduced, thus achieving the optimum service life for the bearings. Recommended position of mating gear is dependent on direction of rotation.

Examples:

Size	Toothed gear drive	V-belt drive
	$\varphi_{\text{opt.}}$	$\varphi_{\text{opt.}}$
10 to 180	$\pm 70^\circ$	$\pm 45^\circ$
200 to 1000	$\pm 45^\circ$	$\pm 70^\circ$

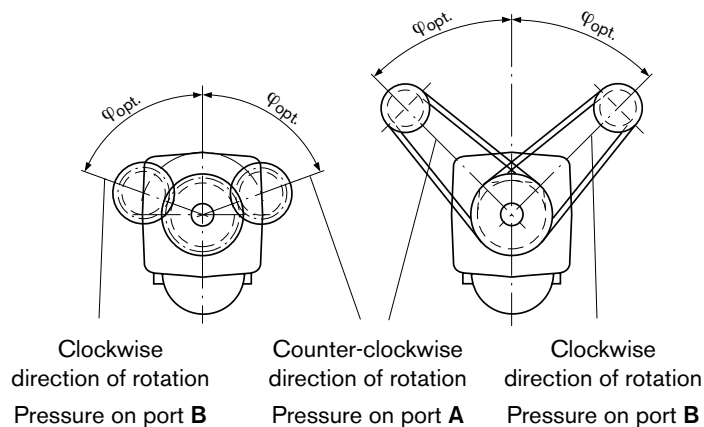

# Ordering Code / Standard Program – Size 5

<b>A2F</b>	<b>5</b>	<b>/</b>	<b>60</b>		<b>-</b>		<b>7</b>
01	02		03	04		05	06

## Axial piston unit

01	Bent axis design, fixed	<b>A2F</b>
----	-------------------------	------------

## Size

02	≈ Displacement $V_{g \max}$ (cm <sup>3</sup> )	<b>5</b>
----	--	----------

## Series

03		<b>60</b>
----	--	-----------

## Direction of rotation

04	Viewed from shaft end	clockwise	<b>R</b>
		counter-clockwise	<b>L</b>

## Shaft end

05	Parallel keyed shaft DIN 6885	<b>B</b>
	Tapered shaft with spigot and spring washer DIN 6888	<b>C</b>

## Service line ports

06	Threads A and B at side, metric	<b>7</b>
----	---------------------------------	----------

Additional instructions in text form

## Seals

The fixed pump A2F5 is equipped with NBR- (nitril-caoutchouc) seals in standard design.

In case of need FKM- (fluor-caoutchouc) seals please indicate when ordering in plain text:

“with FKM-seals”

## Unit Dimensions, Size 5

Before finalizing your design, please request a binding installation drawing. Dimensions in mm.

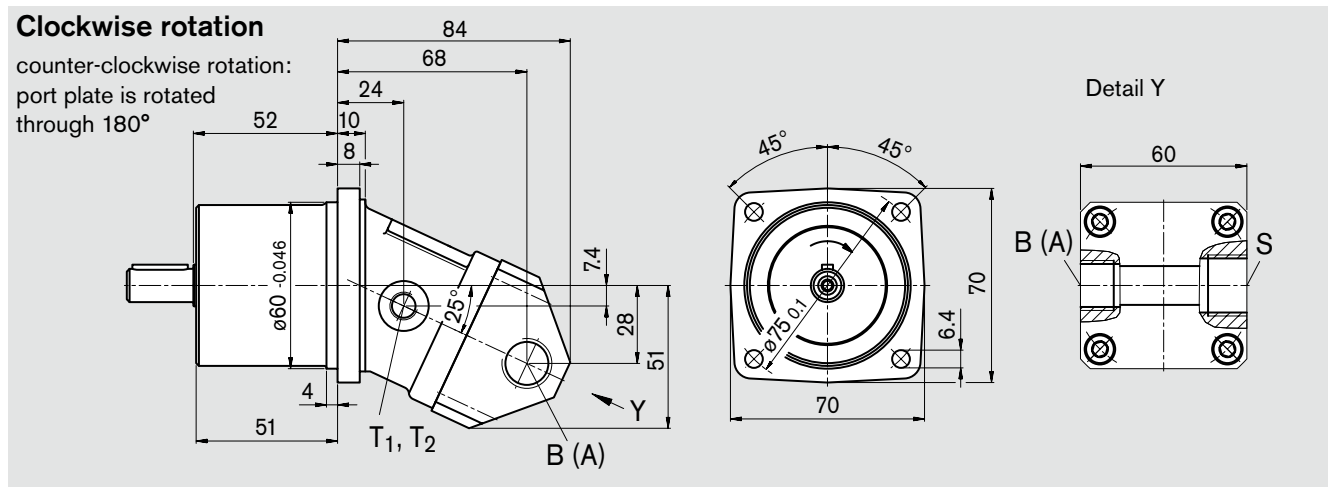

## Shaft ends

**B** Parallel keyed shaft, DIN 6885, A4x4x20  
 $p_N = 210$  bar

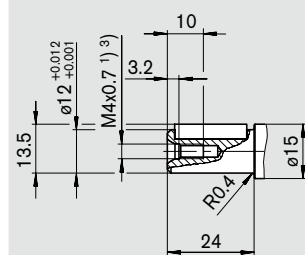

**C** Tapered shaft with spigot and spring washer 3x5  
DIN 6888,  $p_N = 315$  bar  
(taper 1:10)

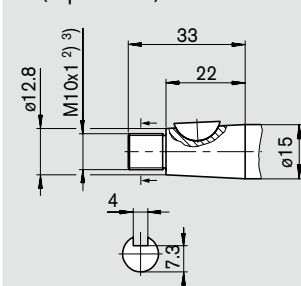

## Ports

B (A)	Service line port DIN 3852	M18x1,5; 12 deep	140 Nm <sup>3)</sup>
S	Suction port DIN 3852	M22x1,5; 14 deep	210 Nm <sup>3)</sup>
T <sub>1</sub> , T <sub>2</sub>	Case drain ports DIN 3852	M10x1; 8 deep	30 Nm <sup>3)</sup>

1) Center bore according to DIN 332  
(thread according to DIN 13)

2) Thread according to DIN 3852, max. tightening torque: 30 Nm

3) Please observe the general notes for the max. tightening torques on page 24



# Unit Dimensions, Sizes 10, 12, 16

Before finalizing your design, please request a binding installation drawing. Dimensions in mm.

## Clockwise rotation

Counter-clockwise rotation: port plate is rotated through 180°

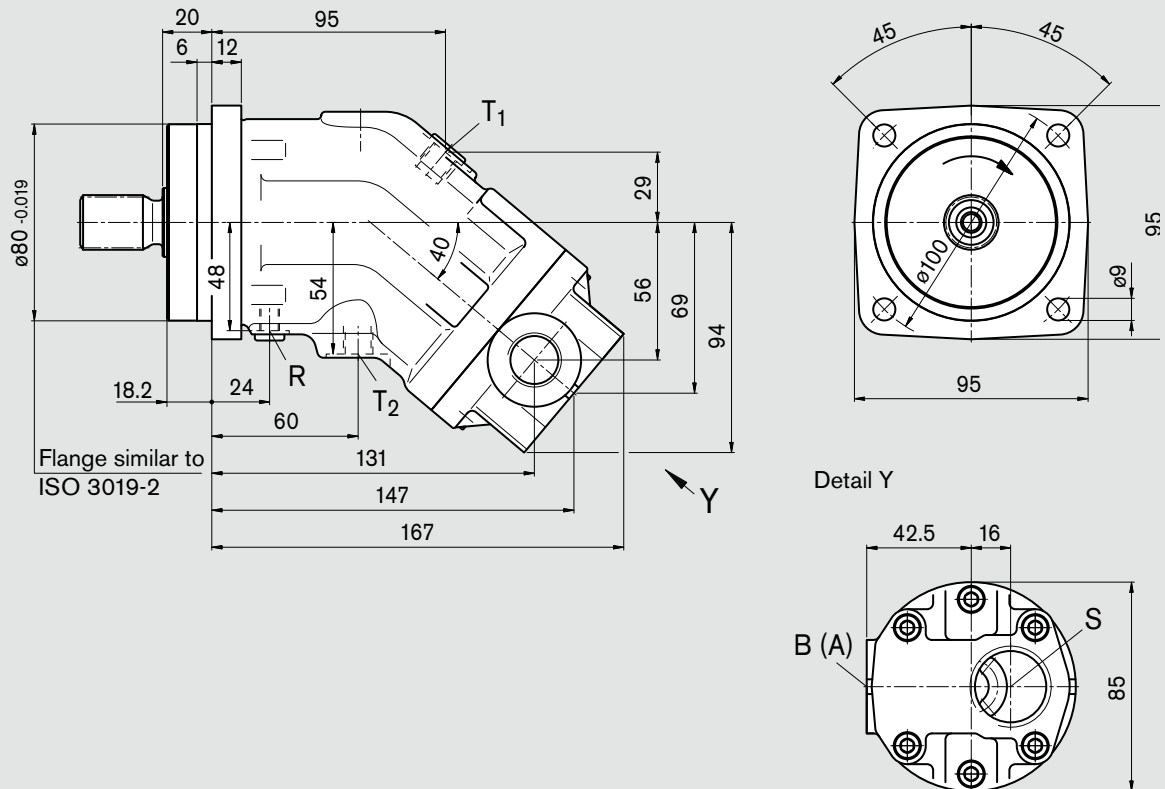

## Shaft ends

### Sizes 10, 12, 16

**A** Splined shaft DIN 5480  
W25x1,25x30x18x9g  
 $p_N = 400$  bar

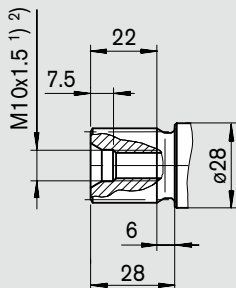

### Sizes 10, 12

**Z** Splined shaft DIN 5480  
W20x1,25x30x14x9g  
 $p_N = 400$  bar

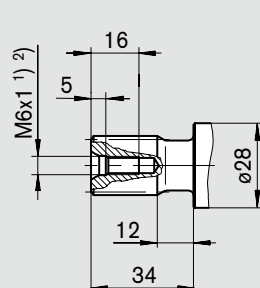

### Sizes 10, 12, 16

**B** Parallel keyed shaft  
DIN 6885, AS8x7x32  
 $p_N = 350$  bar

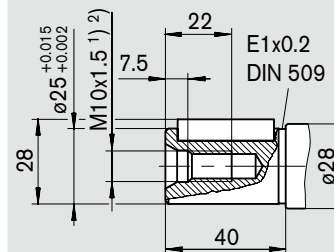

### Sizes 10, 12

**P** Parallel keyed shaft  
DIN 6885, A6x6x32  
 $p_N = 350$  bar

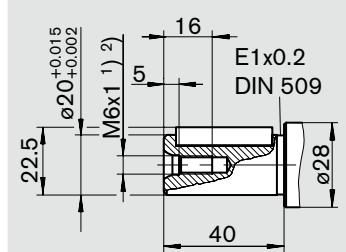

## Ports

B (A)	Service line port	DIN 3852	M22x1,5; 14 deep	210 Nm <sup>2)</sup>
S	Suction port	DIN 3852	M33x2; 18 deep	540 Nm <sup>2)</sup>
T <sub>1</sub> , T <sub>2</sub>	Case drain ports (T <sub>1</sub> plugged)	DIN 3852	M12x1,5; 12 deep	50 Nm <sup>2)</sup>
R	Air bleed (plugged)	DIN 3852	M8x1; 8 deep	10 Nm <sup>2)</sup>

<sup>1)</sup> Center bore according to DIN 332 (thread according to DIN 13)

<sup>2)</sup> Please observe the general notes for the max. tightening torques on page 24

# Unit Dimensions, Sizes 23, 28, 32

Before finalizing your design, please request a binding installation drawing. Dimensions in mm.

## Clockwise rotation

Counter-clockwise rotation: port plate is rotated through 180°

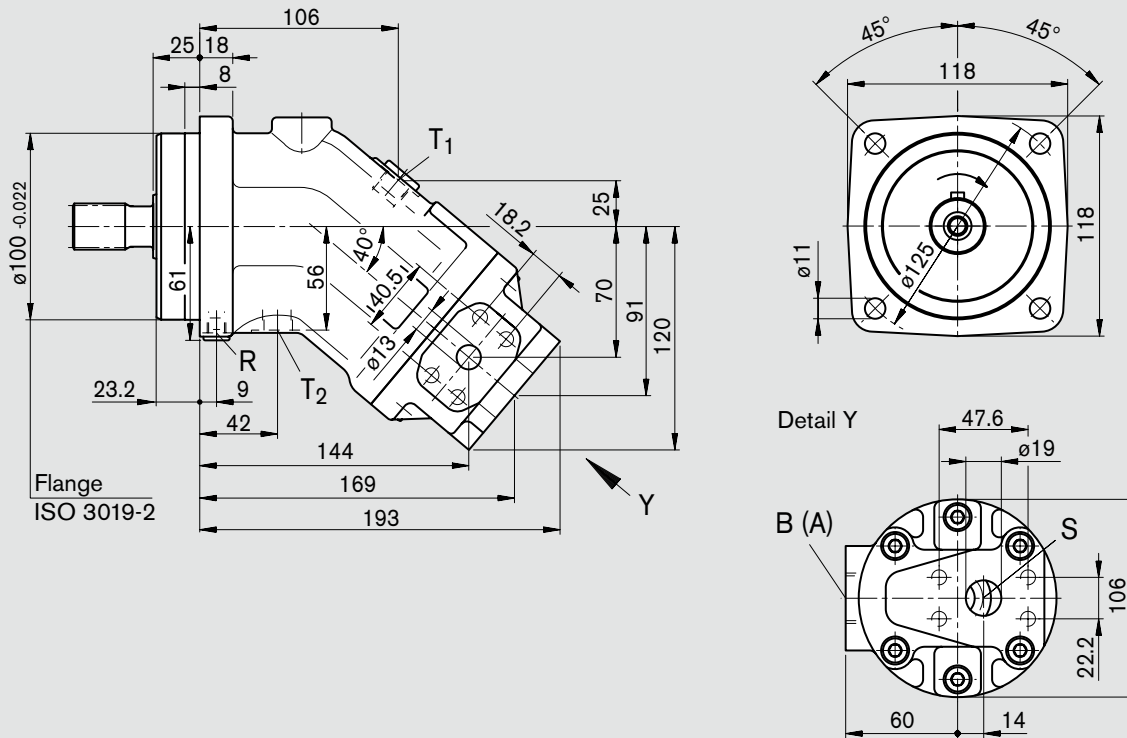

## Shaft ends

### Sizes 23, 28, 32

**A** Splined shaft DIN 5480  
W30x2x30x14x9g  
 $p_N = 400$  bar

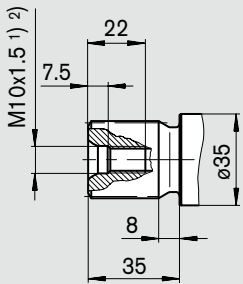

### Sizes 23, 28

**Z** Splined shaft DIN 5480  
W25x1,25x30x18x9g  
 $p_N = 400$  bar

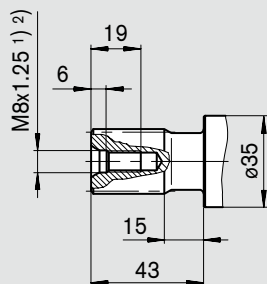

### Sizes 23, 28, 32

**B** Parallel keyed shaft  
DIN 6885, AS8x7x40  
 $p_N = 350$  bar

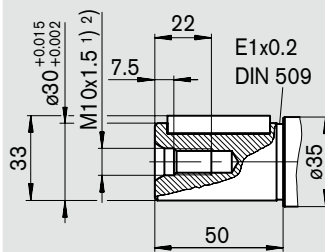

### Sizes 23, 28

**P** Parallel keyed shaft  
DIN 6885, AS8x7x40  
 $p_N = 350$  bar

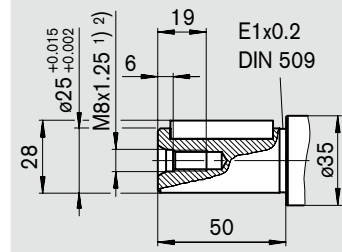

## Ports

B (A)	Service line port (high pressure series) Fastening threads B/A	SAE J518 DIN13	1/2 in M8x1,25; 15 deep <sup>2)</sup>	-
S	Suction port (standard pressure series) Fastening thread S	SAE J518 DIN13	3/4 in M10x1,5; 17 deep <sup>2)</sup>	-
T <sub>1</sub> , T <sub>2</sub>	Case drain ports (T <sub>1</sub> plugged)	DIN 3852	M16x1,5; 14 deep	100 Nm <sup>2)</sup>
R	Air bleed (plugged)	DIN 3852	M10x1; 12 deep	30 Nm <sup>2)</sup>

<sup>1)</sup> Center bore according to DIN 332 (thread according to DIN 13)

<sup>2)</sup> Please observe the general notes for the max. tightening torques on page 24

# Unit Dimensions, Size 45

Before finalizing your design, please request a binding installation drawing. Dimensions in mm.

## Clockwise rotation

Counter-clockwise rotation: port plate is rotated through 180°

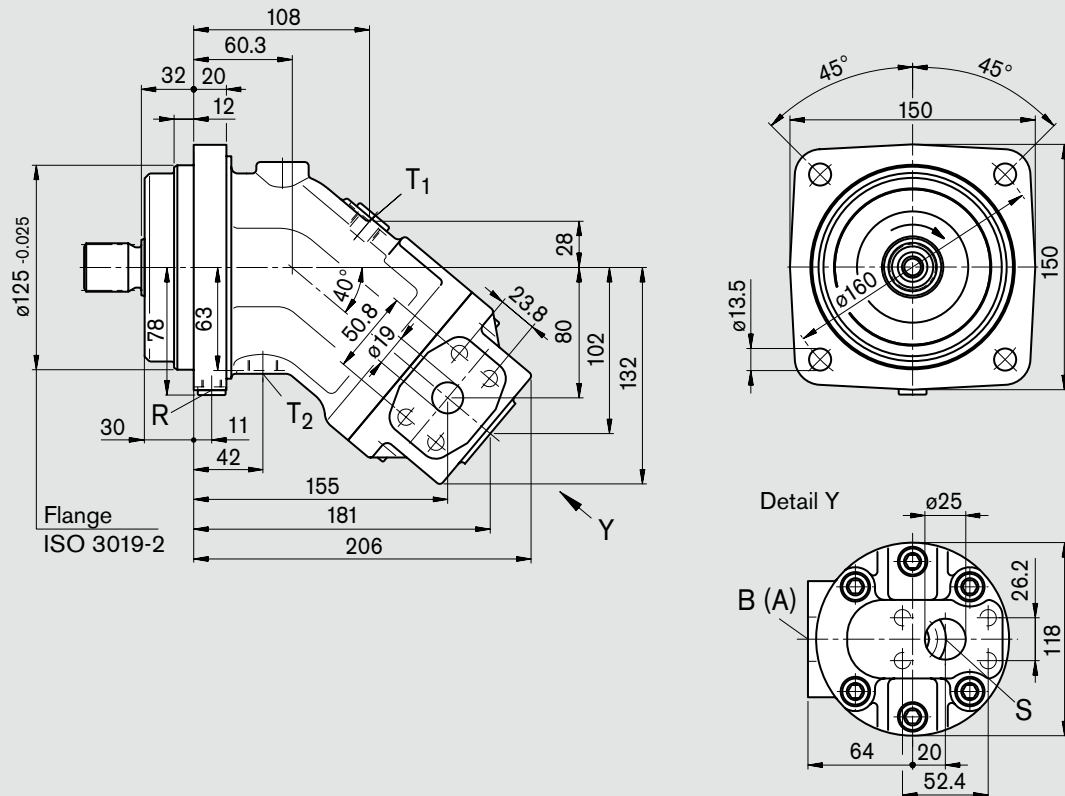

## Shaft ends

**Z** Splined shaft DIN 5480  
W30x2x30x14x9g  
 $p_N = 400$  bar

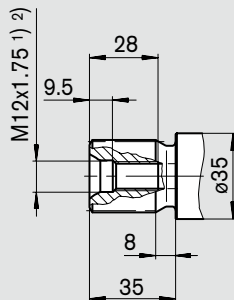

**P** Parallel keyed shaft  
DIN 6885, AS8x7x50  
 $p_N = 350$  bar

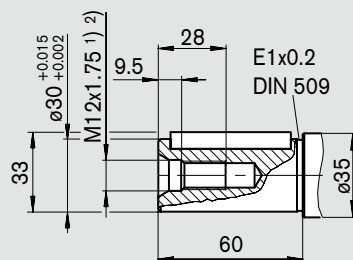

## Ports

B (A)	Service line port (high pressure series) Fastening threads B/A	SAE J518 DIN13	3/4 in M10x1,5; 17 deep <sup>2)</sup>	–
S	Suction port (standard pressure series) Fastening threads S	SAE J518 DIN13	1 in M10x1,5; 17 deep <sup>2)</sup>	–
T <sub>1</sub> , T <sub>2</sub>	Case drain ports (T <sub>1</sub> plugged)	DIN 3852	M18x1,5; 14 deep	140 Nm <sup>2)</sup>
R	Air bleed (plugged)	DIN 3852	M12x1,5; 12 deep	80 Nm <sup>2)</sup>

<sup>1)</sup> Center bore according to DIN 332 (thread according to DIN 13)

<sup>2)</sup> Please observe the general notes for the max. tightening torques on page 24

# Unit Dimensions, Sizes 56, 63

Before finalizing your design, please request a binding installation drawing. Dimensions in mm.

## Clockwise rotation

Counter-clockwise rotation: port plate is rotated through 180°

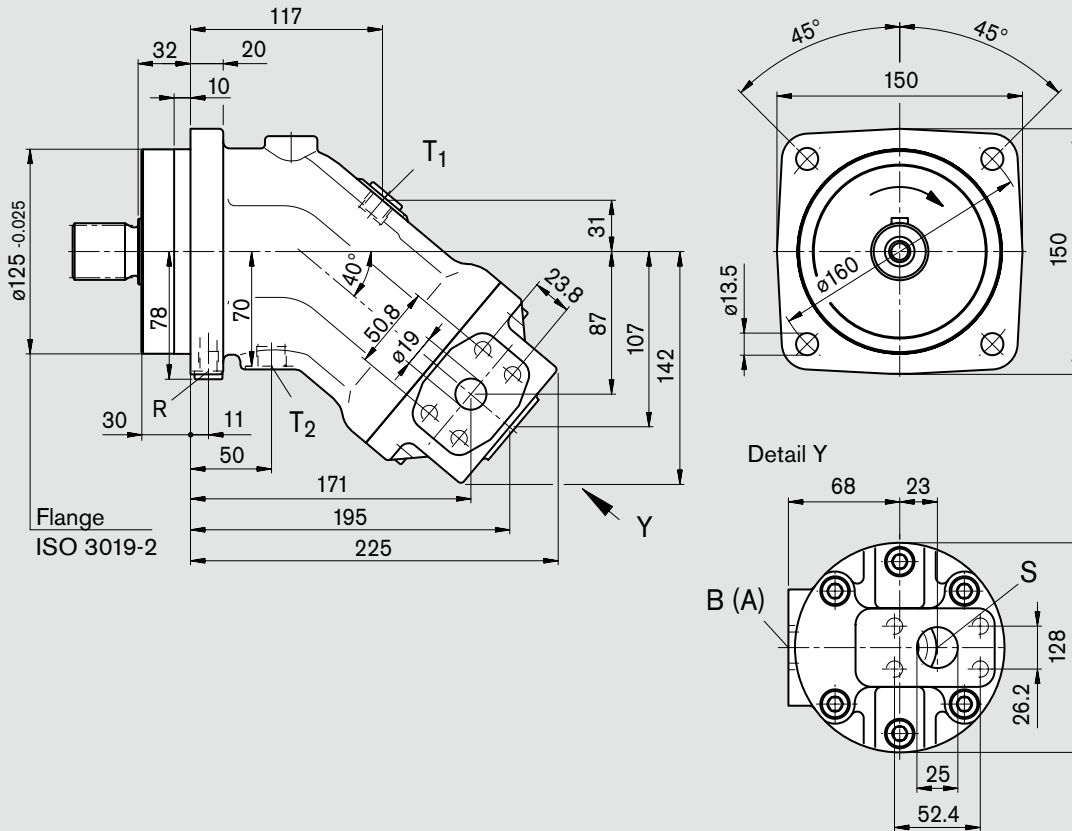

## Shaft ends

### Sizes 56, 63

**A** Splined shaft DIN 5480  
W35x2x30x16x9g  
 $p_N = 400$  bar

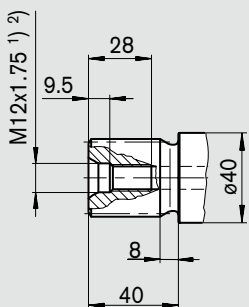

### Size 56

**Z** Splined shaft DIN 5480  
W30x2x30x14x9g  
 $p_N = 350$  bar

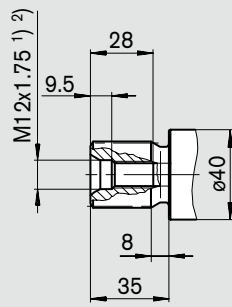

### Sizes 56, 63

**B** Parallel keyed shaft  
DIN 6885, AS10x8x50  
 $p_N = 350$  bar

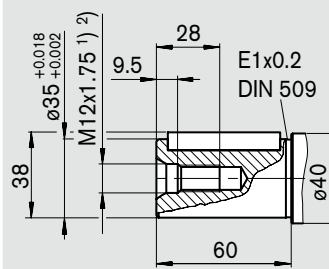

### Size 56

**P** Parallel keyed shaft  
DIN 6885, AS8x7x50  
 $p_N = 350$  bar

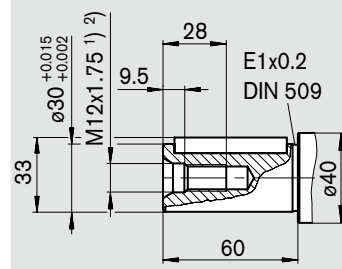

## Ports

B (A)	Service line port (high pressure series) Fastening threads B/A	SAE J518 DIN13	3/4 in M10x1,5; 17 deep <sup>2)</sup>	-
S	Suction port (standard pressure series) Fastening thread S	SAE J518 DIN13	1 in M10x1,5; 17 deep <sup>2)</sup>	-
T <sub>1</sub> , T <sub>2</sub>	Case drain ports (T <sub>1</sub> plugged)	DIN 3852	M18x1,5; 14 deep	140 Nm <sup>2)</sup>
R	Air bleed (plugged)	DIN 3852	M12x1,5; 12 deep	80 Nm <sup>2)</sup>

<sup>1)</sup> Center bore according to DIN 332 (thread according to DIN 13)

<sup>2)</sup> Please observe the general notes for the max. tightening torques on page 24

# Unit Dimensions, Sizes 80, 90

Before finalizing your design, please request a binding installation drawing. Dimensions in mm.

## Clockwise rotation

Counter-clockwise rotation: port plate is rotated through 180°

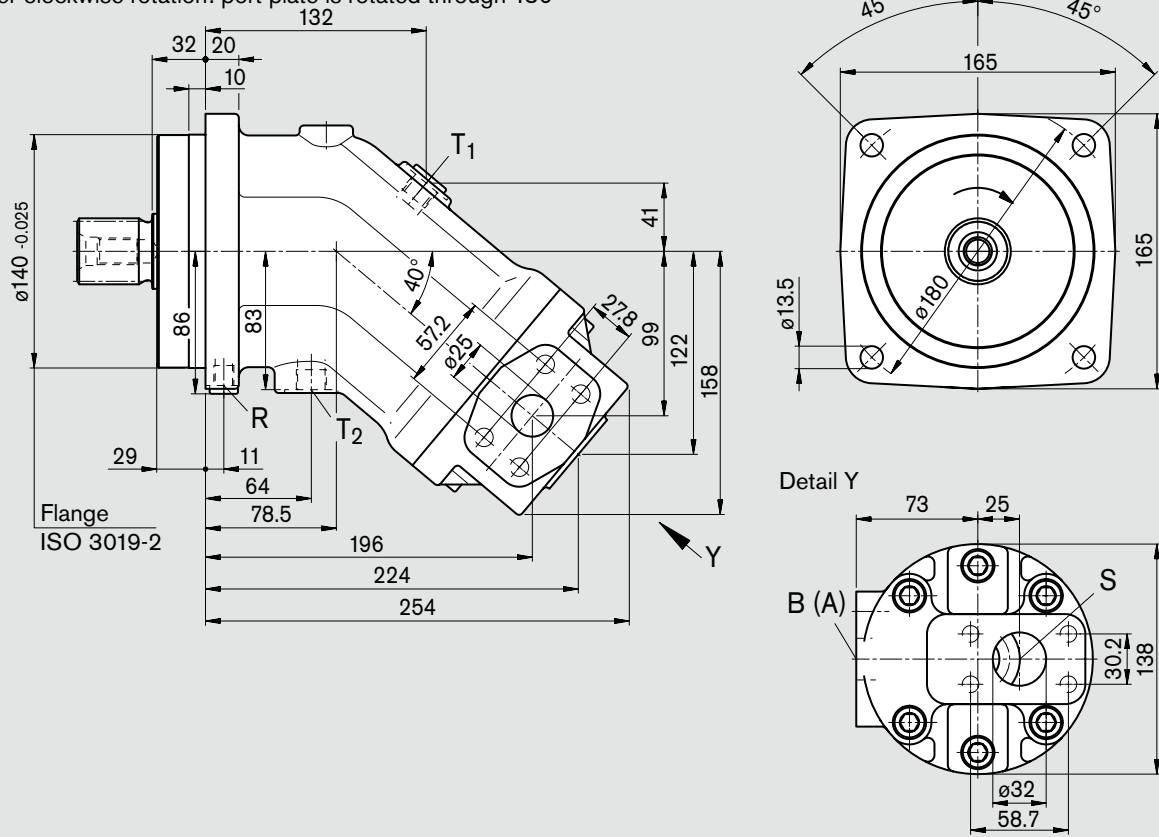

## Shaft ends

### Sizes 80, 90

**A** Splined shaft DIN 5480  
W40x2x30x18x9g  
 $p_N = 400$  bar

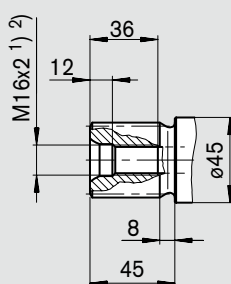

### Size 80

**Z** Splined shaft DIN 5480  
W35x2x30x16x9g  
 $p_N = 400$  bar

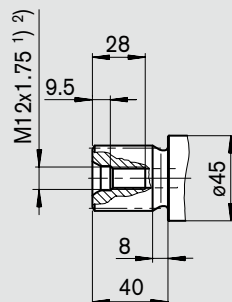

### Sizes 80, 90

**B** Parallel keyed shaft  
DIN 6885, AS12x8x56  
 $p_N = 350$  bar

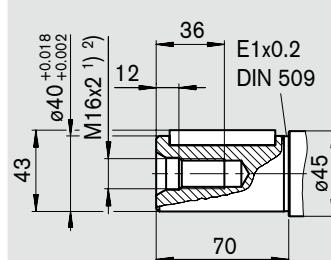

### Size 80

**P** Parallel keyed shaft  
DIN 6885, AS10x8x56  
 $p_N = 350$  bar

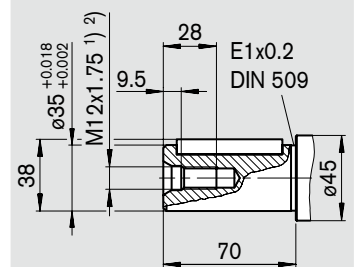

## Ports

B (A)	Service line port (high pressure series) Fastening threads B/A	SAE J518 DIN13	1 in M12x1,5; 17 deep <sup>2)</sup>	–
S	Suction port (standard pressure series) Fastening thread S	SAE J518 DIN13	1 1/4 in M10x1,5; 17 deep <sup>2)</sup>	–
T <sub>1</sub> , T <sub>2</sub>	Case drain ports (T <sub>1</sub> plugged)	DIN 3852	M18x1,5; 14 deep	140 Nm <sup>2)</sup>
R	Air bleed (plugged)	DIN 3852	M12x1,5; 12 deep	80 Nm <sup>2)</sup>

<sup>1)</sup> Center bore according to DIN 332 (thread according to DIN 13)

<sup>2)</sup> Please observe the general notes for the max. tightening torques on page 24

# Unit Dimensions, Sizes 107, 125

Before finalizing your design, please request a binding installation drawing. Dimensions in mm.

## Clockwise rotation

Counter-clockwise rotation: port plate is rotated through 180°  
(dimensions for size 107 in bracket)

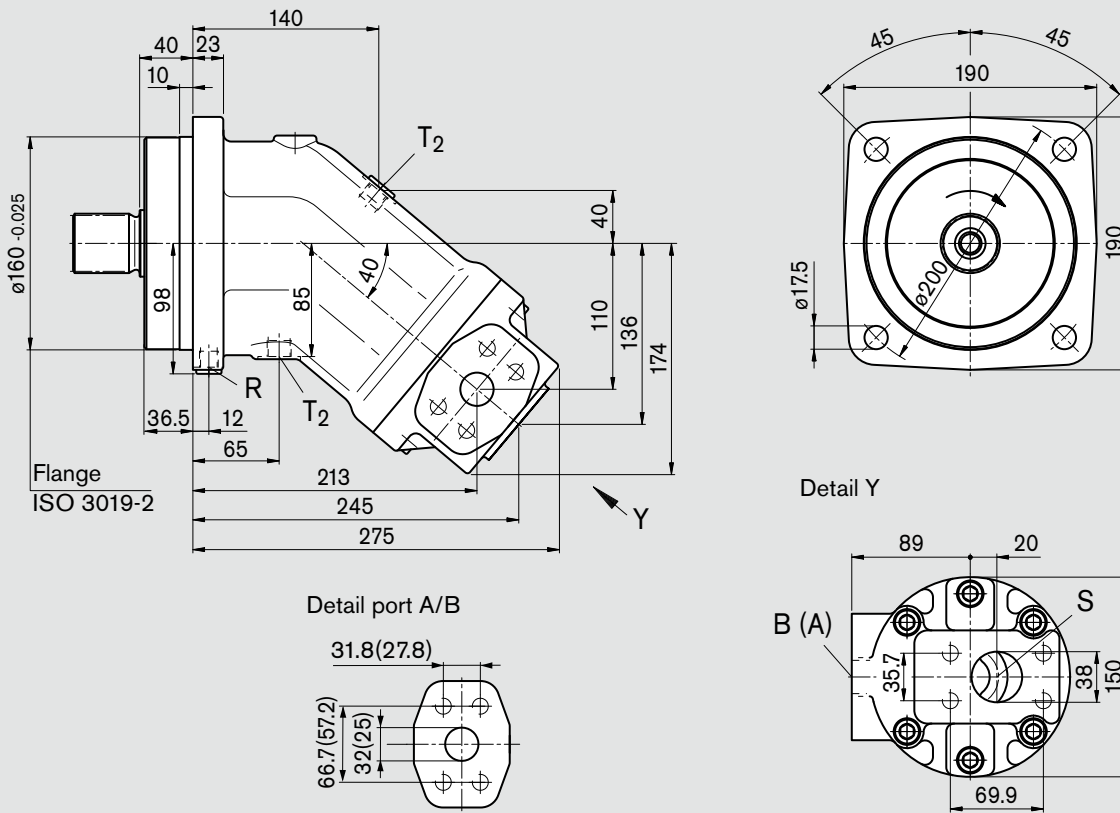

## Shaft ends

### Sizes 107, 125

**A** Splined shaft DIN 5480  
W45x2x30x21x9g  
 $p_N = 400$  bar

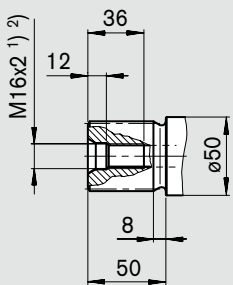

### Size 107

**Z** Splined shaft DIN 5480  
W40x2x30x18x9g  
 $p_N = 400$  bar

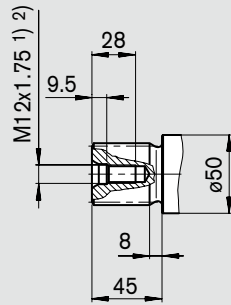

### Sizes 107, 125

**B** Parallel keyed shaft  
DIN 6885, AS14x9x63  
 $p_N = 350$  bar

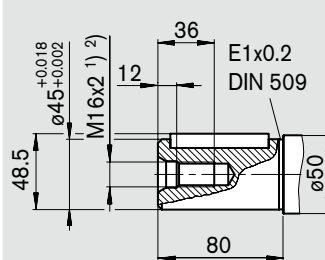

### Size 107

**P** Parallel keyed shaft  
DIN 6885, AS12x8x63  
 $p_N = 350$  bar

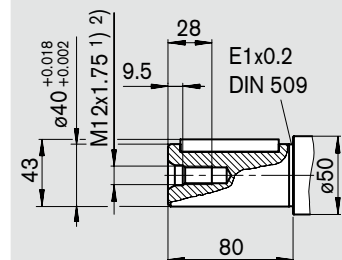

## Ports

B (A)	Service line port (high pressure series)	SAE J518	1 in (size 107)	—
	Fastening threads B/A	SAE J518	1 1/4 in (size 125)	—
S	Suction port (standard pressure series)	DIN13	M12x1,75; 17 deep (size 107) <sup>2)</sup>	—
	Fastening thread S	DIN13	M14x2; 19 deep (size 125) <sup>2)</sup>	—
T <sub>1</sub> , T <sub>2</sub>	Case drain ports (T <sub>1</sub> plugged)	SAE J518	1 1/2 in	—
		DIN13	M12x1,75; 20 deep <sup>2)</sup>	—
R	Air bleed (plugged)	DIN 3852	M18x1,5; 14 deep	140 Nm <sup>2)</sup>
		DIN 3852	M14x1,5; 12 deep	80 Nm <sup>2)</sup>

<sup>1)</sup> Center bore according to DIN 332 (thread according to DIN 13)

<sup>2)</sup> Please observe the general notes for the max. tightening torques on page 24

# Unit Dimensions, Sizes 160, 180

Before finalizing your design, please request a binding installation drawing. Dimensions in mm.

## Clockwise rotation

Counter-clockwise rotation: port plate is rotated through 180°

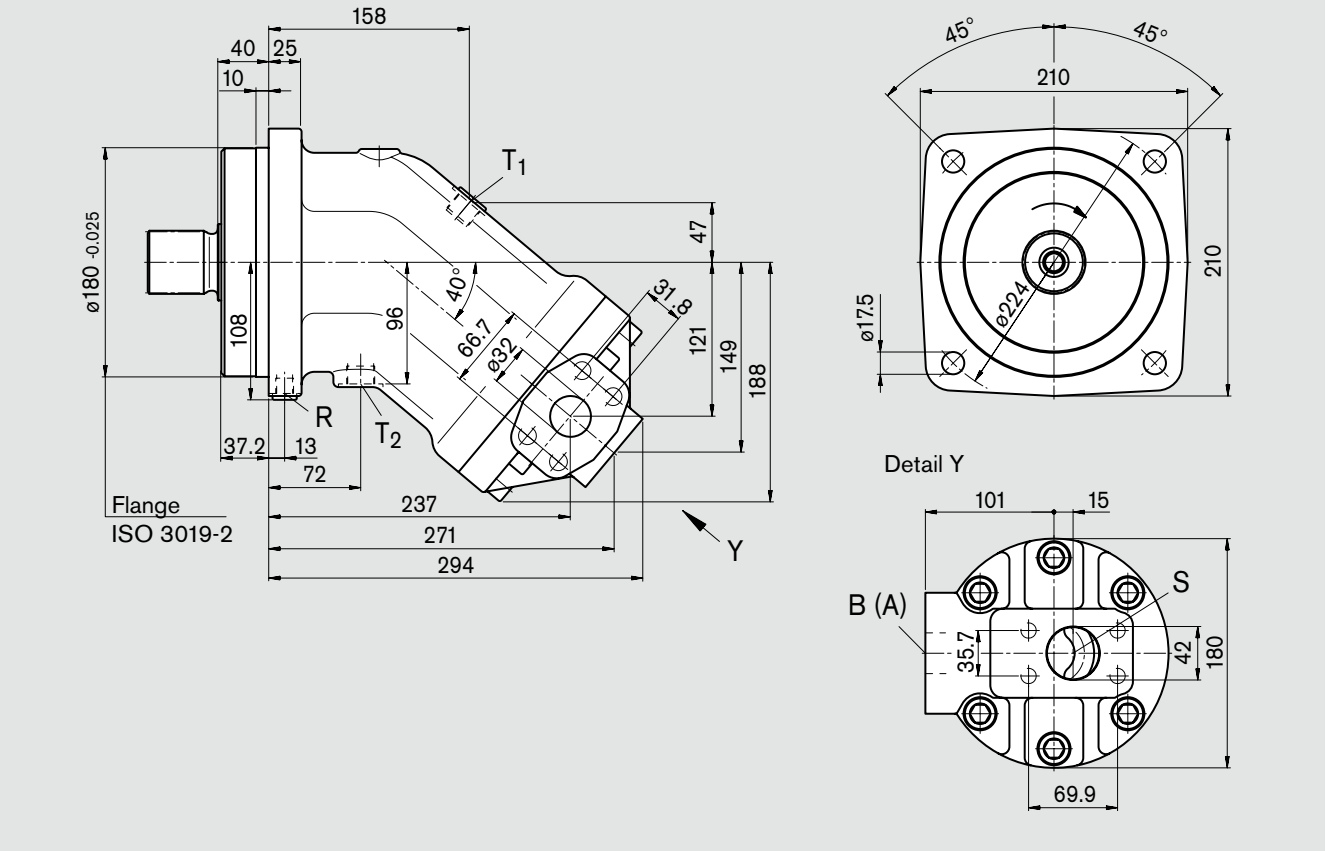

## Shaft ends

### Sizes 160, 180

**A** Splined shaft DIN 5480  
W50x2x30x24x9g  
 $p_N = 400$  bar

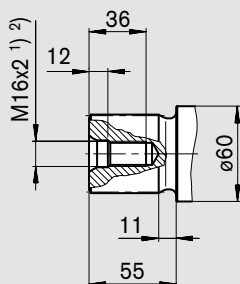

### Size 160

**Z** Splined shaft DIN 5480  
W45x2x30x21x9g  
 $p_N = 400$  bar

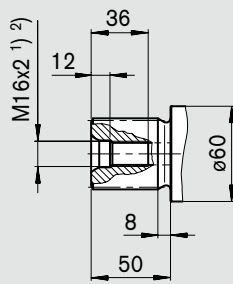

### Sizes 160, 180

**B** Parallel keyed shaft  
DIN 6885, AS14x9x70  
 $p_N = 350$  bar

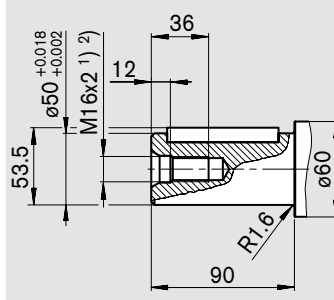

### Size 160

**P** Parallel keyed shaft  
DIN 6885, AS14x9x70  
 $p_N = 350$  bar

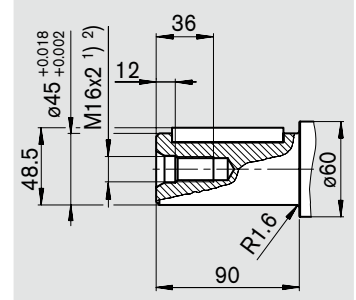

## Ports

B (A)	Service line port (high pressure series) Fastening threads B/A	SAE J518 DIN13	1 1/4 in M14x2; 19 deep <sup>2)</sup>	-
S	Suction port (standard pressure series) Fastening thread S	SAE J518 DIN13	1 1/2 in M12x1,75; 20 deep <sup>2)</sup>	-
T <sub>1</sub> , T <sub>2</sub>	Case drain ports (T <sub>1</sub> plugged)	DIN 3852	M22x1,5; 14 deep	210 Nm <sup>2)</sup>
R	Air bleed (plugged)	DIN 3852	M14x1,5; 12 deep	80 Nm <sup>2)</sup>

<sup>1)</sup> Center bore according to DIN 332 (thread according to DIN 13)

<sup>2)</sup> Please observe the general notes for the max. tightening torques on page 24

# Unit Dimensions, Size 200

Before finalizing your design, please request a binding installation drawing. Dimensions in mm.

## Clockwise rotation

Counter-clockwise rotation: port plate is rotated through 180°

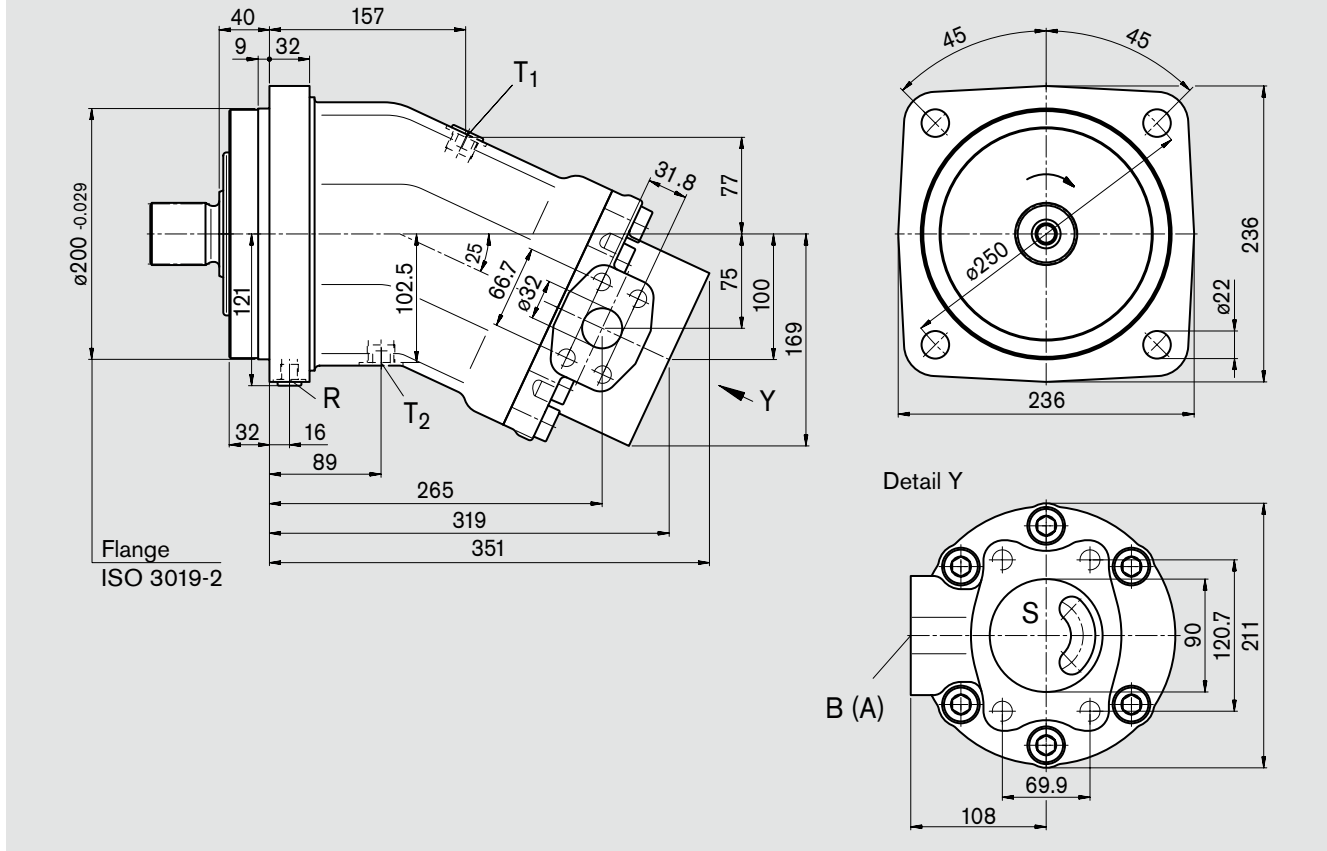

## Shaft ends

**A** Splined shaft DIN 5480  
W50x2x30x24x9g  
 $p_N = 400$  bar

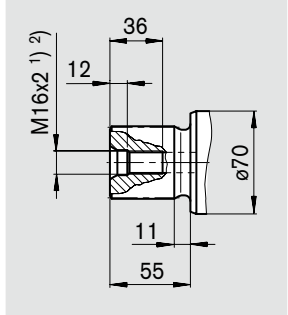

**B** Parallel keyed shaft  
DIN 6885, AS14x9x80  
 $p_N = 350$  bar

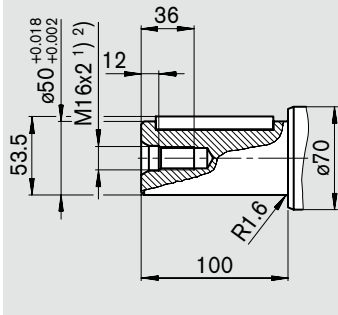

## Ports

B (A)	Service line port (high pressure series) Fastening threads B/A	SAE J518 DIN13	1 1/4 in M14x2; 19 deep <sup>2)</sup>	-
S	Suction port (standard pressure series) Fastening thread S	SAE J518 DIN13	3 1/2 in M16x2; 24 deep <sup>2)</sup>	-
T <sub>1</sub> , T <sub>2</sub>	Case drain ports (T <sub>1</sub> plugged)	DIN 3852	M22x1,5; 14 deep	210 Nm <sup>2)</sup>
R	Air bleed (plugged)	DIN 3852	M14x1,5; 12 deep	80 Nm <sup>2)</sup>

<sup>1)</sup> Centering bore according to DIN 332 (thread according to DIN 13)

<sup>2)</sup> Please observe the general notes for the max. tightening torques on page 24





# Unit Dimensions, Size 355

Before finalizing your design, please request a binding installation drawing. Dimensions in mm.

## Clockwise rotation

Counter-clockwise rotation:  
port plate is rotated  
through 180°

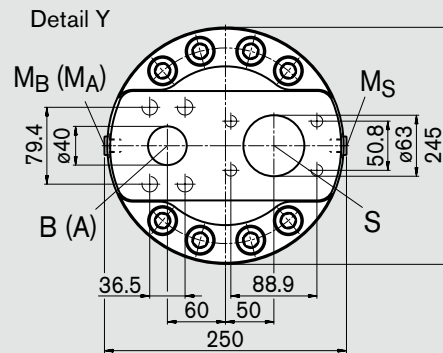
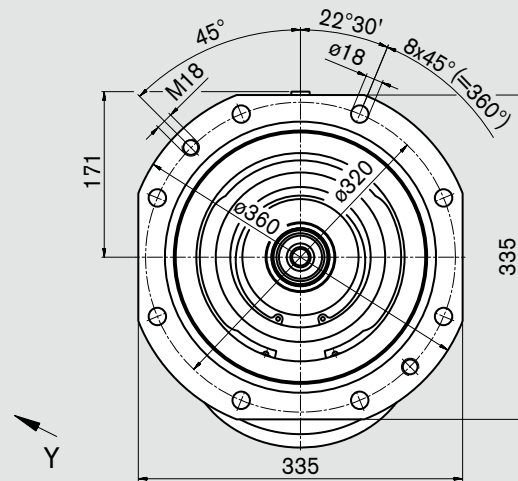
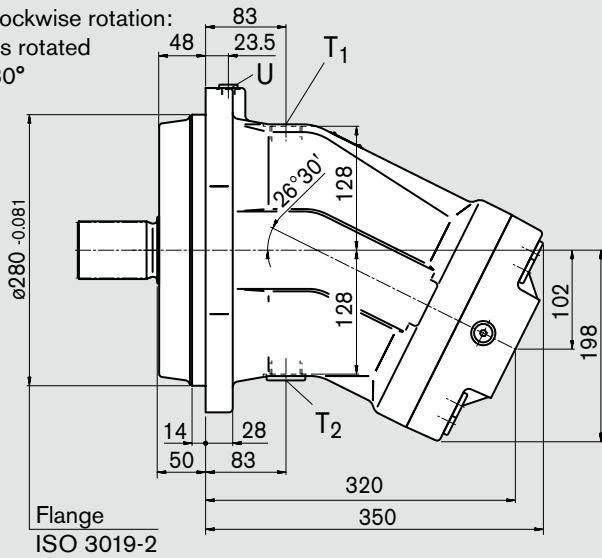

## Shaft ends

**Z** Splined shaft DIN 5480  
W60x2x30x28x9g  
 $p_N = 350$  bar

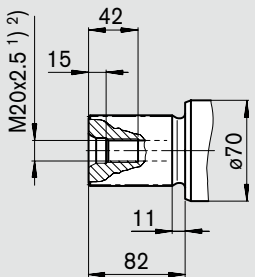

**P** Parallel keyed shaft  
DIN 6885, AS18x11x100  
 $p_N = 350$  bar

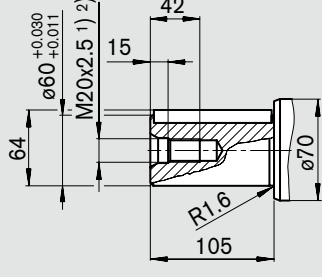

## Ports

B (A)	Service line port (high pressure series) Fastening threads B/A	SAE J518 DIN13	1 1/2 in M16x2; 21 deep <sup>2)</sup>	-
S	Suction port (standard pressure series) Fastening thread S	SAE J518 DIN13	2 1/2 in M12x1,75; 17 deep <sup>2)</sup>	-
T <sub>1</sub> , T <sub>2</sub>	Case drain ports (T <sub>2</sub> plugged)	DIN 3852	M33x2; 18 deep	540 Nm <sup>2)</sup>
U	Port for bearing flushing (plugged)	DIN 3852	M14x1,5; 12 deep	80 Nm <sup>2)</sup>
M <sub>A</sub> , M <sub>B</sub>	Gauge ports operating pressure A, B (plugged)	DIN 3852	M14x1,5; 12 deep	80 Nm <sup>2)</sup>
M <sub>S</sub>	Gauge port suction pressure (plugged)	DIN 3852	M14x1,5; 12 deep	80 Nm <sup>2)</sup>

<sup>1)</sup> Center bore according to DIN 332 (thread according to DIN 13)

<sup>2)</sup> Please observe the general notes for the max. tightening torques on page 24

# Unit Dimensions, Size 500

Before finalizing your design, please request a binding installation drawing. Dimensions in mm.

## Clockwise rotation

Counter-clockwise rotation:  
port plate is rotated  
through 180°

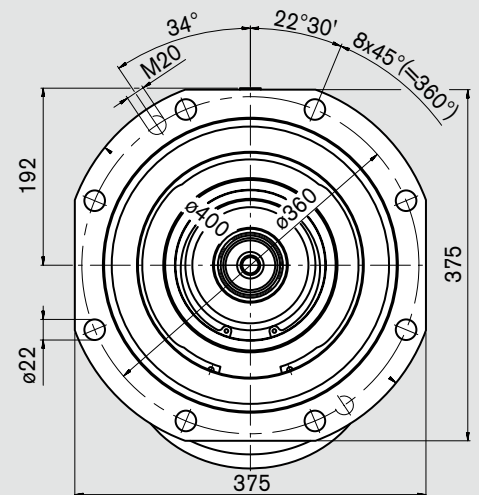
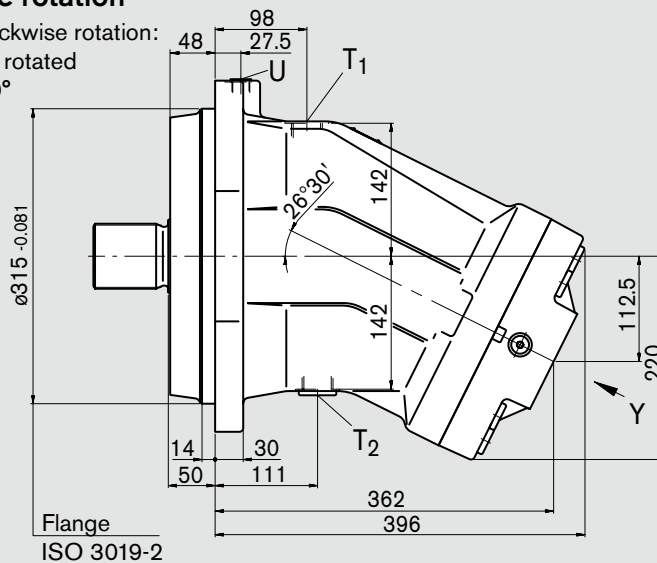

## Detail Y

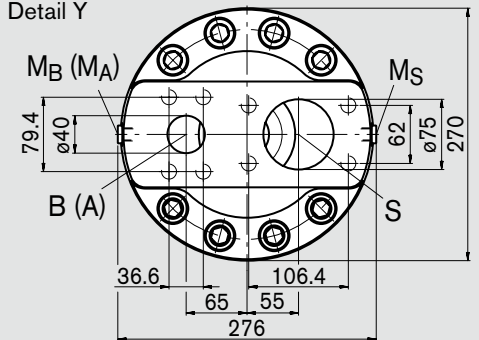

## Shaft ends

**Z** Splined shaft DIN 5480  
W70x3x30x22x9g  
 $p_N = 350$  bar

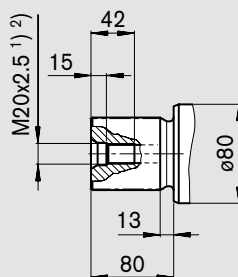

**P** Parallel keyed shaft  
DIN 6885, AS20x12x100  
 $p_N = 350$  bar

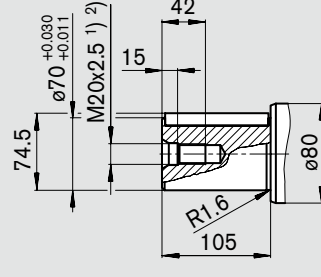

## Ports

B (A)	Service line port (high pressure series) Fastening threads B/A	SAE J518 DIN13	1 1/2 in M16x2; 24 deep <sup>2)</sup>	–
S	Suction port (standard pressure series) Fastening thread S	SAE J518 DIN13	3 in M16x2; 24 deep <sup>2)</sup>	–
T <sub>1</sub> , T <sub>2</sub>	Case drain ports (T <sub>2</sub> plugged)	DIN 3852	M33x2; 18 deep	540 Nm <sup>2)</sup>
U	Port for bearing flushing (plugged)	DIN 3852	M18x1,5; 12 deep	140 Nm <sup>2)</sup>
M <sub>A</sub> , M <sub>B</sub>	Gauge ports operating pressure A, B (plugged)	DIN 3852	M14x1,5; 12 deep	80 Nm <sup>2)</sup>
M <sub>S</sub>	Gauge port suction pressure (plugged)	DIN 3852	M14x1,5; 12 deep	80 Nm <sup>2)</sup>

<sup>1)</sup> Center bore according to DIN 332 (thread according to DIN 13)

<sup>2)</sup> Please observe the general notes for the max. tightening torques on page 24

# Unit Dimensions, Size 710

Before finalizing your design, please request a binding installation drawing. Dimensions in mm.

## Clockwise rotation

Counter-clockwise rotation:  
port plate is rotated  
through 180°

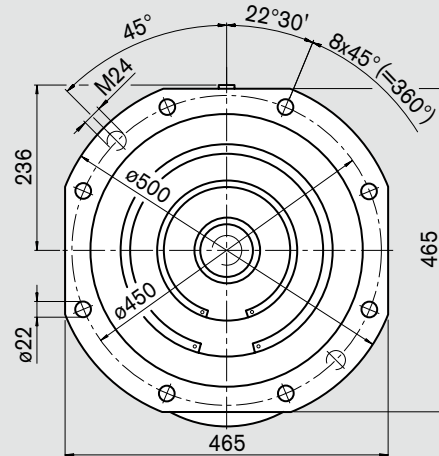
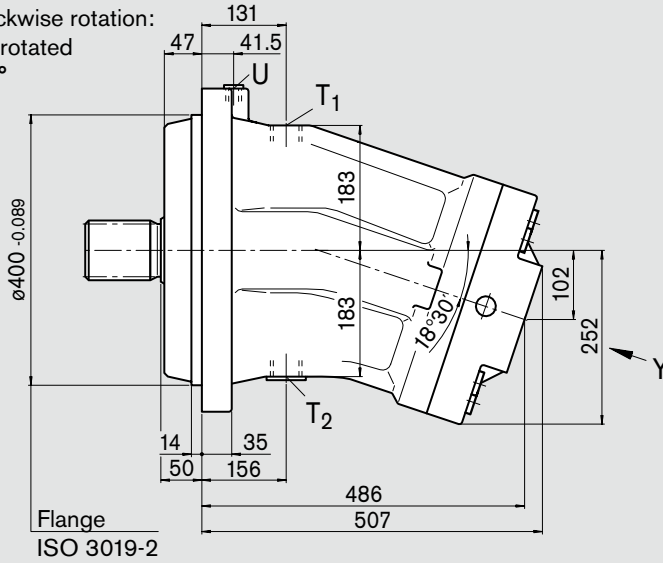

## Detail Y

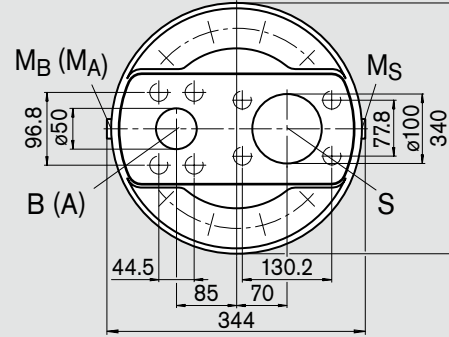

## Shaft ends

**Z** Splined shaft DIN 5480  
W90x3x30x28x9g  
p<sub>N</sub> = 350 bar

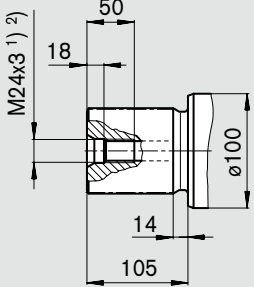

**P** Parallel keyed shaft  
DIN 6885, AS25x14x125  
p<sub>N</sub> = 350 bar

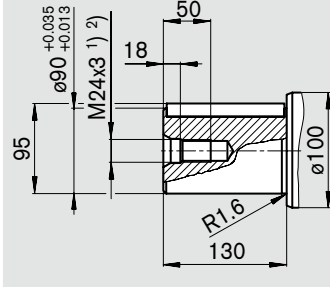

## Ports

B (A)	Service line port (high pressure series) Fastening threads B/A	SAE J518 DIN13	2 in M20x2,5; 30 deep <sup>2)</sup>	-
S	Suction port (standard pressure series) Fastening thread S	SAE J518 DIN13	4 in M16x2; 24 deep <sup>2)</sup>	-
T <sub>1</sub> , T <sub>2</sub>	Case drain ports (T <sub>2</sub> plugged)	DIN 3852	M42x2; 20 deep	720 Nm <sup>2)</sup>
U	Port for bearing flushing (plugged)	DIN 3852	M18x1,5; 12 deep	140 Nm <sup>2)</sup>
M <sub>A</sub> , M <sub>B</sub>	Gauge ports operating pressure A, B (plugged)	DIN 3852	M14x1,5; 12 deep	80 Nm <sup>2)</sup>
M <sub>S</sub>	Gauge port suction pressure (plugged)	DIN 3852	M14x1,5; 12 deep	80 Nm <sup>2)</sup>

<sup>1)</sup> Center bore according to DIN 332 (thread according to DIN 13)

<sup>2)</sup> Please observe the general notes for the max. tightening torques on page 24

# Unit Dimensions, Size 1000

Before finalizing your design, please request a binding installation drawing. Dimensions in mm.

## Clockwise rotation

Counter-clockwise rotation:  
port plate is rotated  
through 180°

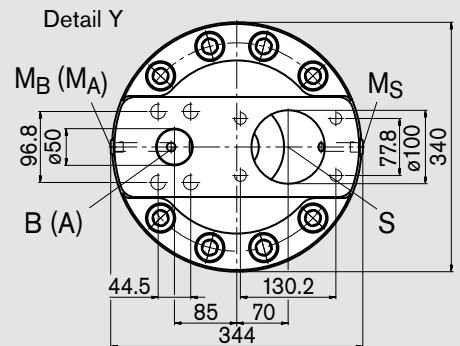
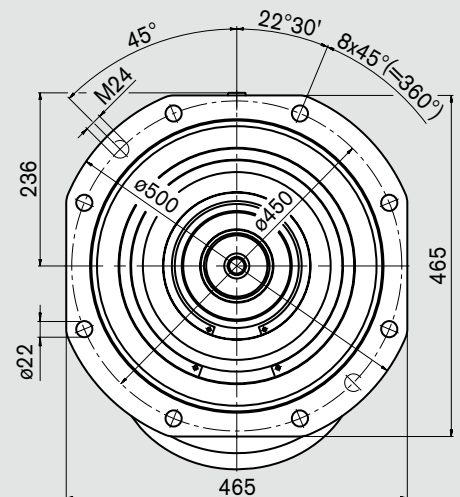
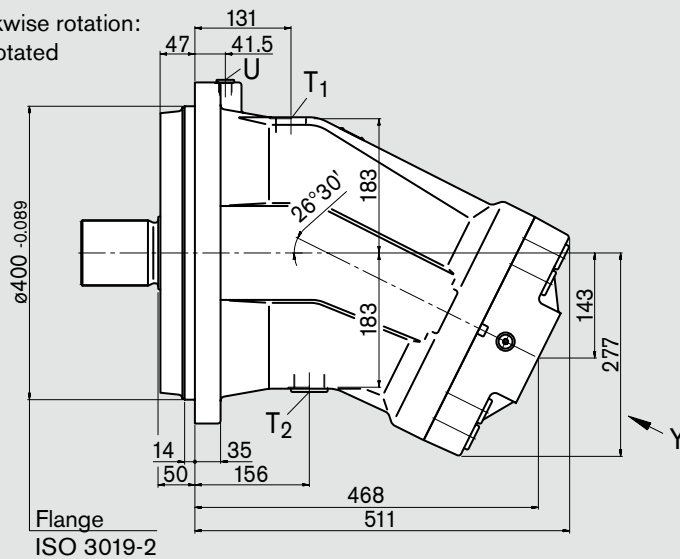

## Shaft ends

**Z** Splined shaft DIN 5480  
W90x3x30x28x9g  
 $p_N = 350$  bar

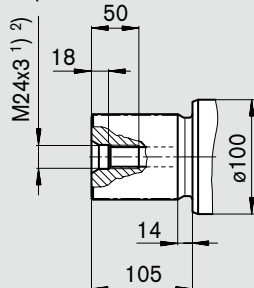

**P** Parallel keyed shaft  
DIN 6885, AS25x14x125  
 $p_N = 350$  bar

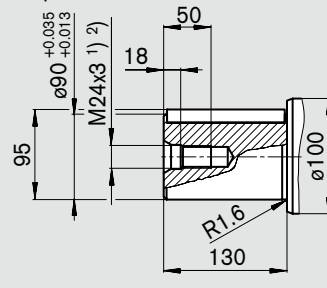

## Ports

B (A)	Service line port (high pressure series) Fastening threads B/A	SAE J518 DIN13	2 in M20x2,5; 30 deep <sup>2)</sup>	–
S	Suction port (standard pressure series) Fastening thread S	SAE J518 DIN13	4 in M16x2; 24 deep <sup>2)</sup>	–
T <sub>1</sub> , T <sub>2</sub>	Case drain ports (T2 plugged)	DIN 3852	M4x2; 20 deep	720 Nm <sup>2)</sup>
U	Port for bearing flushing (plugged)	DIN 3852	M18x1,5; 12 deep	140 Nm <sup>2)</sup>
M <sub>A</sub> , M <sub>B</sub>	Gauge ports operating pressure A, B (plugged)	DIN 3852	M14x1,5; 12 deep	80 Nm <sup>2)</sup>
M <sub>S</sub>	Gauge port suction pressure (plugged)	DIN 3852	M14x1,5; 12 deep	80 Nm <sup>2)</sup>

<sup>1)</sup> Center bore according to DIN 332 (thread according to DIN 13)

<sup>2)</sup> Please observe the general notes for the max. tightening torques on page 24

# Installation notes

## General

The pump case must be completely filled up with hydraulic fluid during startup and during operation (filling the case chamber). The pump must be started up at low speed and no load until the system has been bled completely.

If stopped for an extended period, fluid may drain out of the case through the service lines. When restarting, make sure that the case contains sufficient fluid.

The leakage fluid inside the case chamber must be drained off to the tank through the highest case drain port. The min. suction pressure at port S must not fall below 0,8 bar absolute (see page 4).

## Installation position

Optional.

### Installation below the tank

Pump below min. fluid level in the tank (standard)

- Fill axial piston pump before startup via the highest case drain port
- Run the pump at low speed until the system is bled completely.
- Minimum immersion depth of leakage line in tank: 200 mm (relative to the min. fluid level in the tank).
- Additional measures required for installation position 2 (shaft facing up): with installation position 2, make sure that the pump case is completely full before starting up. Bleed at port R (sizes 10 to 200) resp. U (sizes 250 to 1000). An air pocket in the bearing area is leading to damage of the axial piston pump.
- Recommendation: Fill up suction lines

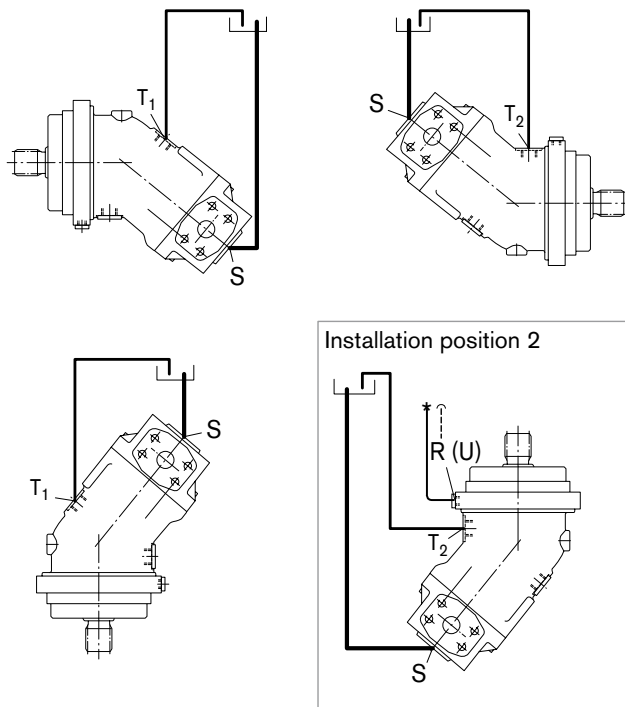

### Installation above the tank

Pump above minimum fluid level in tank

- Proceed in same way as below the tank installation
- Additional measures for installation positions 1 and 2:  
If stopped for an extended period, fluid may drain out of the case chamber through the service lines (air enters through the shaft seal). The bearings will therefore not be properly lubricated when the pump is started up again. Fill the axial piston pump before restarting via the highest case drain port. Installation position 2: bleed at port R (sizes 10 to 200) resp. U (sizes 250 to 1000).
- Additional measures required for installation position 2 (shaft facing up):  
In this installation position the bearings will not be properly lubricated, even if there is still some fluid in the case chamber. Putting a non-return valve (opening pressure 0,5 bar) in the leakage line can prevent the system emptying through the line.
- Note: min. admissible pressure at port S (min. suction pressure see page 5)

#### Installation position 1

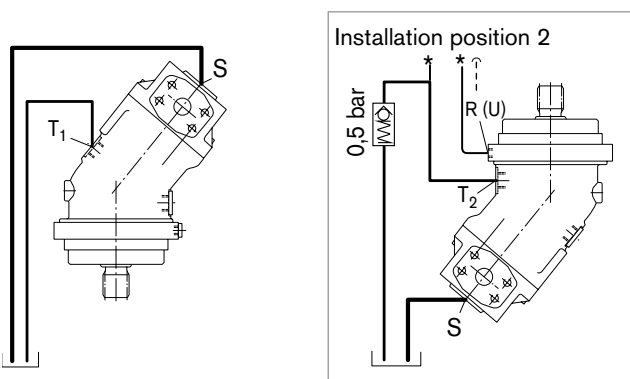
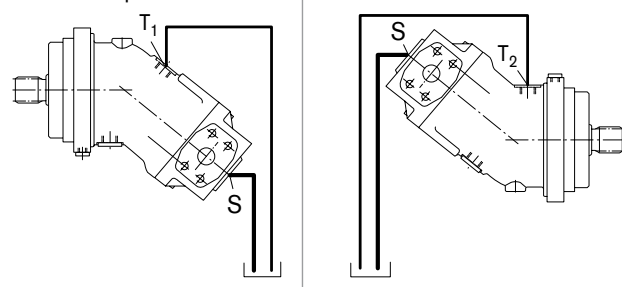

**Notes**

## General Notes

- The A2FO pump is designed to be used in open circuits.
- Project planning, assembly, and commissioning of the pump require the involvement of qualified personnel.
- The service line ports and function ports are only designed to accommodate hydraulic lines.
- During and shortly after operation, there is a risk of burns on the pump. Take suitable safety precautions, e.g. wear protective clothing
- There may be shifts in the characteristic depending on the operating state of the pump (operating pressure, fluid temperature).
- Tightening torques:
  - The tightening torques specified in this data sheet are maximum values and must not be exceeded (maximum values for screw thread).  
Manufacturer's instruction for the max. permissible tightening torques of the used fittings must be observed!
  - For DIN 13 fixing screws, we recommend checking the tightening torque individually according to VDI 2230 Edition 2003.
- The data and information contained herein must be adhered to.

Bosch Rexroth AG  
Hydraulics  
Product Segment Axial Piston Units  
Elchingen Plant  
Glockeraustrasse 2  
89275 Elchingen, Germany  
Phone +49 (0) 73 08 82-0  
Facsimile +49 (0) 73 08 72 74  
info.brm-ak@boschrexroth.de  
www.boschrexroth.com/axial-piston-pumps

Horb Plant  
An den Kelterwiesen 14  
72160 Horb, Germany  
Phone +49 (0) 74 51 92-0  
Facsimile +49 (0) 74 51 82 21

© This document, as well as the data, specifications and other information set forth in it, are the exclusive property of Bosch Rexroth AG. It may not be reproduced or given to third parties without its consent.

The data specified above only serve to describe the product. No statements concerning a certain condition or suitability for a certain application can be derived from our information. The information given does not release the user from the obligation of own judgment and verification. It must be remembered that our products are subject to a natural process of wear and aging.

Subject to change.